

Datasheet opticlink™ 1394 models



Key features

- IEEE1394 (FireWire) video interface
- available in three models:
 - 400 MT and 400 LC: up to 400 Mbps data transfer rate
 - 800 LC: up to 800 Mbps data transfer rate
- up to 500 meter fiber cable length
- two electrical ports and one optical port
- 400 LC and 800 LC are equipped with the LC-duplex fiber connector conform the IEEE1394 specification
- 400 MT is equipped with the MT-RJ fiber connector
- full compatibility with FireWire™, SB1394™ and i.LINK™
- supports a wide range of devices: video, mass storage, still cameras etc.
- hot pluggable
- optionally compliant to IDB-1394 specification (only 800 LC model)
- fiber link benefits:
 - does not radiate
 - is not susceptible of electromagnetic interference
 - difficult to tap (secure connection)
 - no grounding problems

General

The opticlink™ 1394 provides long haul IEEE1394 transmission over fiber optics cable. This interface can be used for transmission of FireWire (video) data up to 500 meter without repeaters.

It is a transparent interface, so it can be applied for various FireWire devices. The opticlink™ 1394 800 LC offers data rates up to 800 megabits per second (Mbps). The 400 LC and 400 MT models offer a the data rate up 400 Mbps.

FireWire is a trademark of Apple Computer Incorporated
i.LINK is a trademark of Sony Corporation
all mentioned trademarks and registered trademarks are acknowledged

System

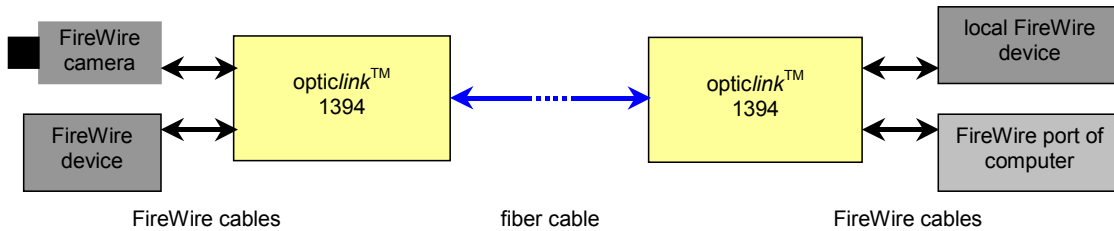

The generated FireWire signals of the camera will be converted to optical signals by the *opticlink™* 1394. The other *opticlink™* unit converts the optical data back to the original FireWire signals, that can be received by a standard FireWire port. The FireWire-fiber-FireWire conversions are entirely transparent, so the camera and framegrabber do not notice the *opticlink™*.

Architecture

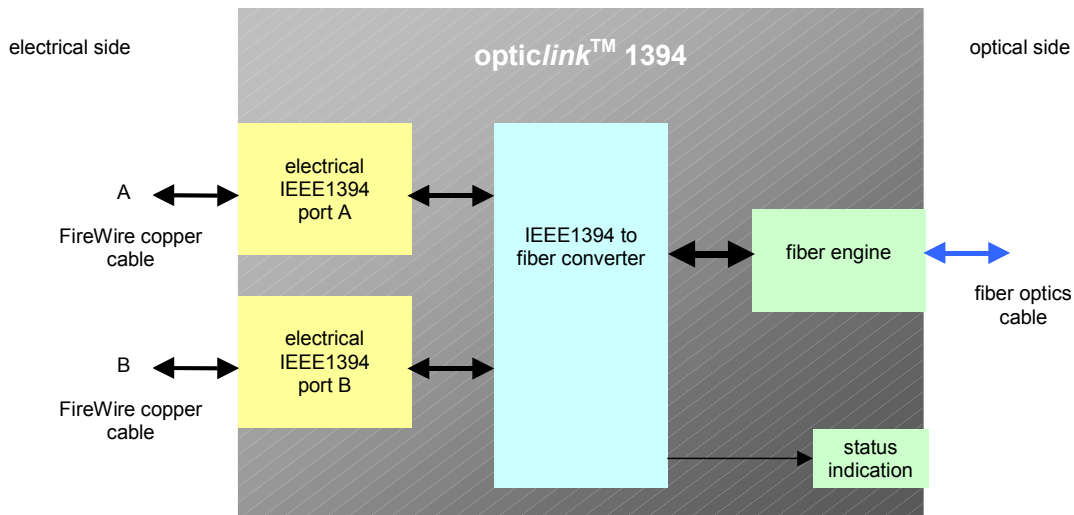

Option: IDB-1394

The *opticlink™* 1394 800 LC is optionally full compliant to the Intelligent Transportation System Data Bus (IDB) 1394, also known as 1394-Automotive or IDB-1394. This standard is an automotive-grade version of the high-speed 400 Mbps IEEE1394 standard. It is developed by the Joint Automotive Working Group, a partnership between IDB Forum and 1394 Trade Association.

The IDB-1394 option offers:

- Extended temperature range: -40°C to 85°C
- Automotive sleep mode support
- Up to 400 Mbps

The *opticlink™* 1394 800 LC is equipped with two 9 pole IDB-1394b connectors.

Power supply

The copper FireWire cable is designed to transport data and power. So FireWire devices (like the *opticlink™* 1394) does not always need an external power supply. There are three situations:

Use power of a computer

The FireWire port of the computer powers the *opticlink™* 1394 by the FireWire copper cable. No external power supply is required.

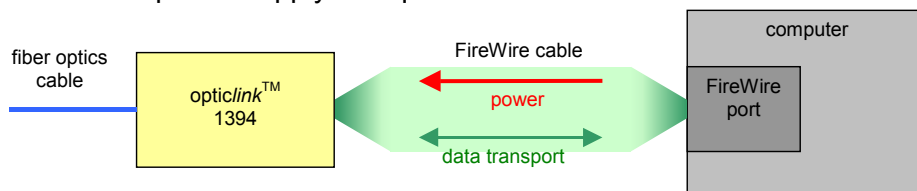

Use power of an external power supply (1)

A FireWire device (eg. a camera) is powered by an external power supply. Via the FireWire copper cable the *opticlink™* 1394 is powered too. The *opticlink™* 1394 doesn't require an external power supply.

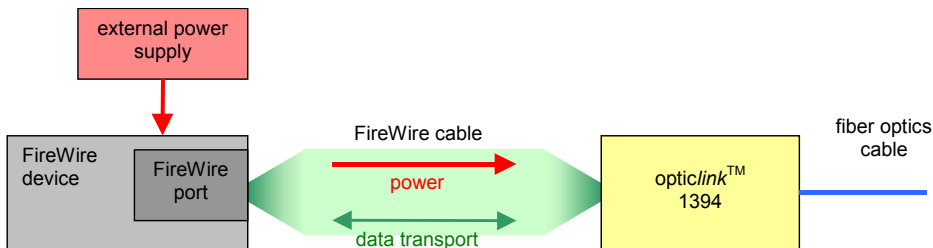

Use power of an external power supply (2)

In this situation the *opticlink™* 1394 is powered by an external power supply. The FireWire copper cable will power the FireWire device too. The external power supply should be compliant to the power specification of the *opticlink™* 1394 and the FireWire device. The *opticlink™* 1394 is able to power 15 W per port.

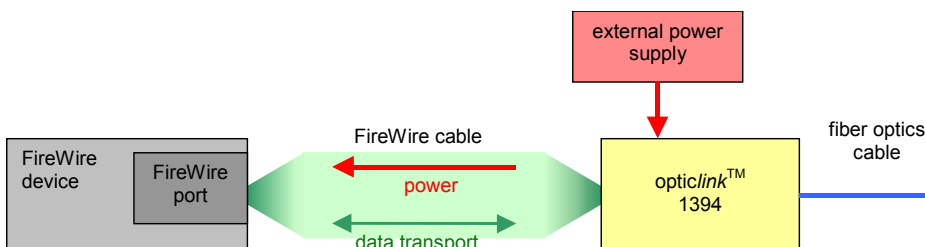

Technical Specifications

opticlink™ 1394			
Model	400 MT	400 LC	800 LC
fiber interface			
Fiber type	multi mode		
Max fiber length	500 meter (50/125µm fiber) 275 meter (62.5/125µm fiber)		
Fiber tranceiver	one full duplex tranceiver		
Fiber connector	1 MT-RJ	1 LC duplex	1 LC duplex
electrical interface			
IEEE Standard compliance	IEEE1394a-2000 1394-1995	IEEE1394a-2000 1394-1995	IEEE1394b-2002 IEEE1394a-2000 1394-1995
Bilingual support	no	no	yes
optional IDB-1394 support	no	no	yes
Data rates (Mbps)	100, 200, 400	100, 200, 400	100, 200, 400, 800 (IDB-1394: up to 400)
Connector	2x 6 pole IEEE1394a-2000	2x 6 pole IEEE1394a-2000	2x 9 pole bilingual IDB 1394b
Max power to external device	15 W (max 1.5 A) per port		
Max copper cable length	4.5 meter		
general			
Dimensions (l x w x h)	80 x 55 x 24 mm	80 x 55 x 24 mm	105 x 105 x 33 mm
Supply voltage	5 V to 40 V (in conformity with the IEEE1394 specification: 8 V to 40 V)		
Power consumption	tbd	tbd	tbd
Power connector	4-pins subminiature round male connector Thomas & Betts: subminiature connector Triad '01' Binder: subminiature 'Circular Series 712'		
Operating temperature	0° C to 70° C	0° C to 70° C	0° C to 70° C (IDB-1394: -40° C to 85° C)



Options

Hardware modification

compliant to IDB-1394 specification
(only 800 LC model)