

# Piranha ES ES-80-0xKx0

Enhanced Sensitivity Line Scan Cameras

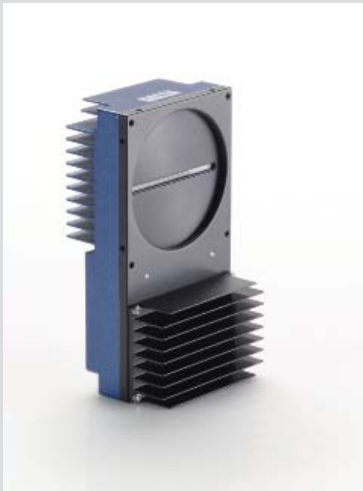

**Piranha ES ES-80-08Kx0**

## Key Features

- 8192 / 4096 pixels
- Up to 68 kHz line rate
- 320 / 640 Mpix / sec
- Responsivity up to 1970 DN/(nJ/cm<sup>2</sup>) @ 0 dB, 12 bit
- 15 second calibration time
- Bidirectional
- Antiblooming
- Configurable Medium or Full Camera Link

## Programmability

- Stage selectability up to 32 stages
- Up to four sets of flat field correction coefficients
- Mirroring and forward/reverse control
- Flat field corrections

## Typical Applications

- Solar cell inspection
- Flat panel display inspection
- Postal sorting (flats)
- High performance document scanning
- Low light applications
- Large web applications

## Overview

# 8k and 4k resolution and 30X greater responsivity than traditional line scan cameras

The Piranha ES camera family represents DALSA's cost effective, enhanced sensitivity TDI based cameras. With a maximum line rate of 68 kHz and throughput up to 640 Mpix / sec, the Piranha ES 8k/4k maximizes system throughput and provides the largest number of pixels available in a TDI camera.

Camera configuration is extremely flexible and the number of Camera Link taps, throughput, and line rate are all software controllable.

All cameras are capable of bidirectionality with up to 32 stages of selectability, while preventing overexposure with antiblooming.

The ES 8k/4k is available in two speed grades so you can select the best camera throughput for your application.

## Specifications

Resolution	8192 / 4096 x 32 TDI
Data Rate	320 / 640 megapixels per second
Max. Line/Frame Rate	34 / 68 kHz
Pixel Size	7 $\mu$ m
Data Format	8, 12 bit
Output	Med, Full Camera Link
Lens Mount	M72 x 0.75
Responsivity	1970 DN/(nJ/cm <sup>2</sup> ) broadband, 12 bit, 0 dB
Dynamic Range	56 dB
Nominal Gain Range	$\pm$ 10 dB
Size	150 mm x 80 mm x 65 mm
Mass	< 800 g
Operating Temp	0 °C to 50 °C
Power Supply	12 V to 15 V
Power Dissipation	19 W
Regulatory Compliance	CE and RoHS
Control	MDR26 Camera Link
Data	Shared with Control
Power	Hirose HR10 6 pin
Example Part Number	ES-80-08k80-00-R

# Piranha ES ES-80-0xKx0

Enhanced Sensitivity Line Scan Cameras

These Enhanced Sensitivity Line Scan cameras use TDI technology to maximize photon capture at these high line rates. With data rates up to 640 megapixels per second and 8k of resolution, these cameras inspect and detect with unrivalled precision and speed.

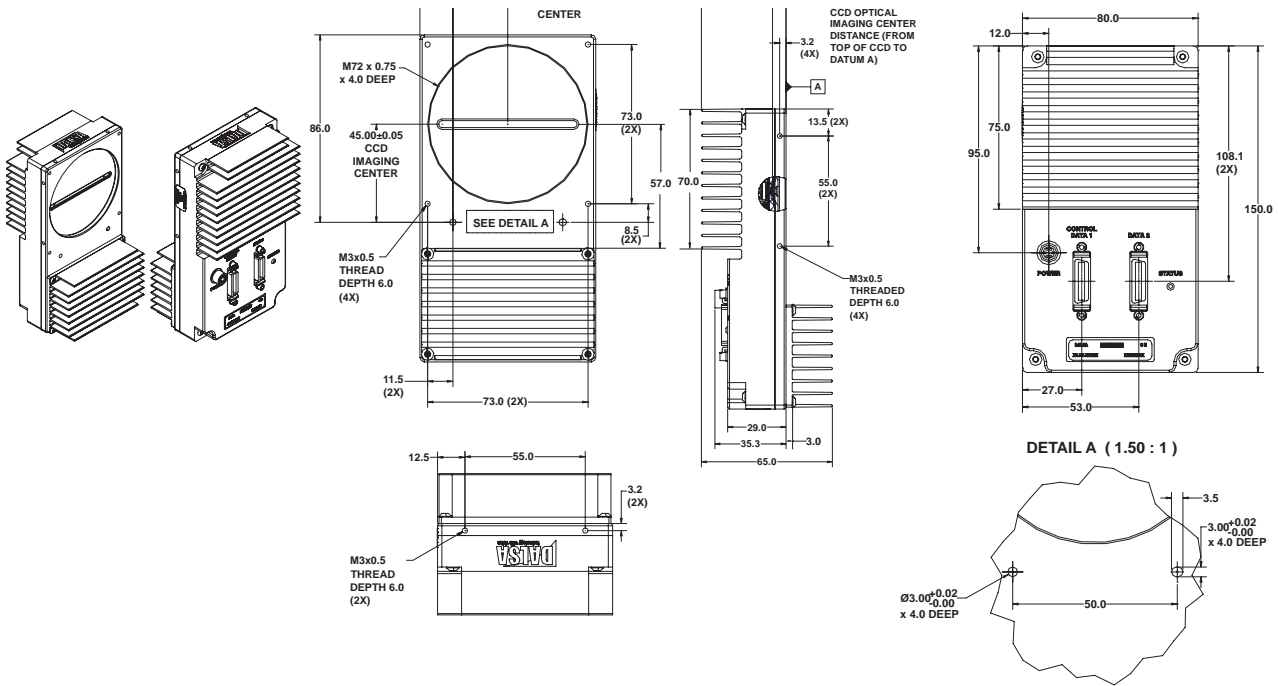
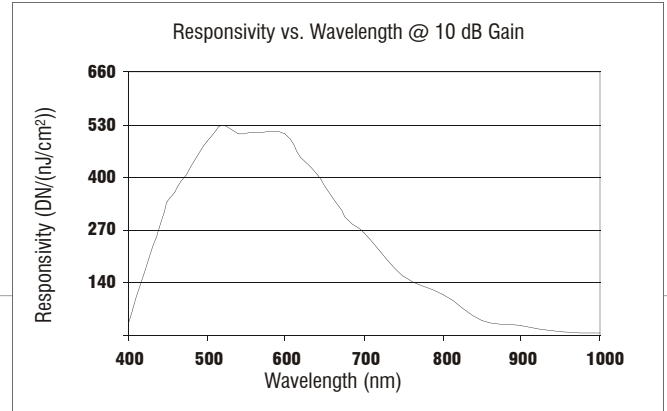

units: mm

[www.dalsa.com](http://www.dalsa.com)

**Americas**  
 Boston, USA  
 Tel: +1 978-670-2000  
 sales.americas@dalsa.com

**Europe**  
 Munich, Germany  
 Tel: +49 8142-46770  
 sales.europe@dalsa.com

**Asia Pacific**  
 Tokyo, Japan  
 +81 3-5960-6353  
 sales.asia@dalsa.com

DALSA is an international leader in digital imaging and semiconductors and has its corporate offices in Waterloo, Ontario, Canada.

All trademarks are registered by their respective companies. DALSA reserves the right to make changes at any time without notice. © DALSA 2008. 03-070-20028-00

